

## Operating instructions

F-RRE/RLE 26020 | F-RRE/RLE 32010 |  
F-RRE/RLE 32020 | F-RRE/RLE 32040 |  
F-RRE/RLE 53020 | F-RRE/RLE 53050 |  
F-RRE/RLE 62010

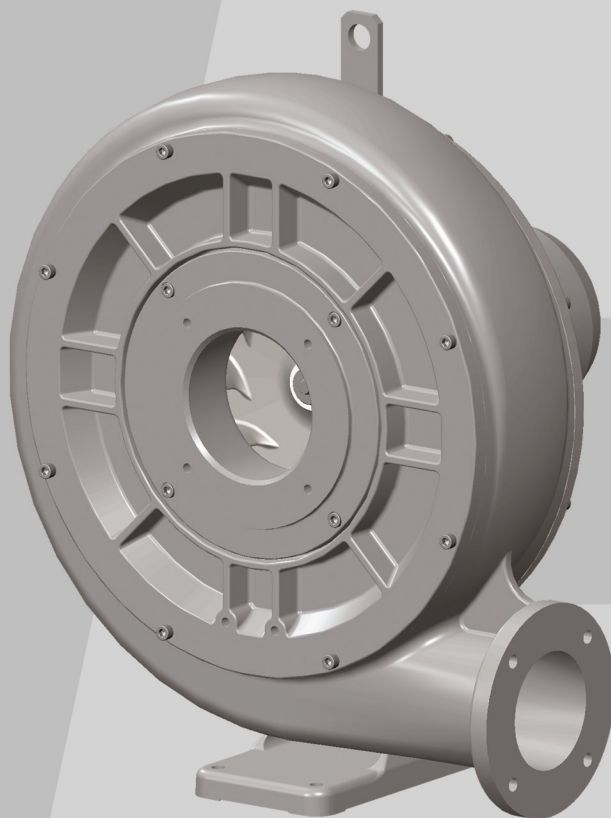

**F-Serie**  
**F-Series**

Radial  
Radial



<b>1</b>	<b>About this manual</b> .....	<b>4</b>
1.1	Content of this document .....	4
1.2	Target group .....	4
1.3	Explanation of the terms and symbols .....	4
1.4	Changes in comparison to the previous version .....	6
<b>2</b>	<b>Safety and responsibility</b> .....	<b>7</b>
2.1	Explanation of warning signs .....	7
2.2	Correct use of the equipment .....	7
2.3	Improper operational modes .....	8
2.4	Working in a safety-conscious manner .....	8
2.5	Requirements for personnel .....	9
2.5.1	Staff qualifications and training .....	9
2.5.2	Personal protective equipment .....	10
2.6	Requirements of the operator .....	11
<b>3</b>	<b>Product identification</b> .....	<b>12</b>
3.1	Rating plate .....	12
3.2	Design of the machine .....	13
3.3	Options .....	14
3.4	Function principle .....	14
3.5	EU declaration of conformity .....	15
<b>4</b>	<b>Transportation and storage</b> .....	<b>16</b>
4.1	Unpacking and checking the condition of delivery .....	16
4.2	Lifting and transporting .....	16
4.3	Storage .....	17
<b>5</b>	<b>Mounting</b> .....	<b>18</b>
5.1	Measures after long-term storage .....	18
5.2	Reduction of oscillations and noises .....	18
5.3	Mounting conditions .....	18
5.4	Set up .....	18
5.5	Connecting pipelines and hoses .....	19
<b>6</b>	<b>Electric power connection</b> .....	<b>21</b>
6.1	General installation regulations .....	21
6.2	Controls .....	22
6.3	Prepare the motor terminal box .....	23
6.4	Connect the motor to the mains .....	23
<b>7</b>	<b>Commissioning</b> .....	<b>24</b>
7.1	Measures after a long shut-down period .....	24
7.2	Tests during commissioning or re-commissioning .....	24
7.3	Check the direction of rotation .....	24
7.4	Power adjustment .....	25
<b>8</b>	<b>Operation</b> .....	<b>26</b>
8.1	Switch on .....	26
8.2	Switch off .....	26
8.3	Switch off in emergency .....	26
<b>9</b>	<b>Troubleshooting</b> .....	<b>27</b>
<b>10</b>	<b>Maintenance, repairs and spare parts</b> .....	<b>29</b>
10.1	Maintenance .....	29
10.2	Repairs and complaints .....	29
<b>11</b>	<b>Decommissioning</b> .....	<b>30</b>
11.1	Decommissioning .....	30
11.2	Disassembly .....	30
11.3	Disposal .....	30

<b>12</b>	<b>Technical data .....</b>	<b>31</b>
12.1	Mechanical data .....	31
12.1.1	Weight .....	31
12.1.2	Tightening torque values .....	31
12.2	Permitted conditions for use .....	31
12.2.1	Installation height .....	31
12.2.2	Rotational speeds .....	31
12.2.3	Temperatures .....	32
12.2.4	Pressure differences .....	32
12.2.5	Relative humidity .....	32
12.2.6	Minimum distances .....	32
12.3	Electrical data .....	33
12.3.1	Increased operating cycle frequency .....	33
12.4	Acoustic emissions .....	33

## 1.1 Content of this document

These operating instructions:

- Is part of the radial blower:

Series	F-RRE/F-RLE	
Types	F-RRE 26020	F-RLE 26020 F-
	F-RRE 32010	RLE 32010 F-
	F-RRE 32020	RLE 32020 F-
	F-RRE 32040	RLE 32040 F-
	F-RRE 53020	RLE 53020 F-
	F-RRE 53050	RLE 53050 F-
	F-RRE 62010	RLE 62010

- describe the safe, proper and efficient use in all phases of its service life.
- must always be available to personnel at the place of use.
- Arranged in the main sections:
  - About these instructions
  - Safety and responsibility
  - Product identification
  - Transportation and storage
  - Mounting
  - Electric power connection
  - Commissioning
  - Operation
  - Troubleshooting
  - Maintenance, repairs and spare parts
  - Decommissioning
  - Technical data



The main section on “Safety and responsibility” must always be observed. The subsequent main sections can be used as a reference and can be read independently from each other. Cross references provided must be observed.







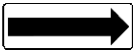



## 1.2 Target group

These instructions are intended for operating personnel, qualified personnel, electricians, operators and planners. See also Staff qualifications and training [→ 9].

## 1.3 Explanation of the terms and symbols

In these instructions symbols and terms will be used to mean the following.

Symbol	Explanation
!	Requirement, pre-requisite
①	One-step handling instructions
1 2 3	Multi-step handling instructions
✓	Result
[→ 54]	Cross reference with page reference
	Additional information, tips
	Direction of rotation arrow
	Direction of conveyance arrow
	General warning sign (warns of risk of injury)

Symbol	Explanation
	Electrical voltage warning
	Hot surface warning
	Disconnect prior to maintenance or repair
	Observe the instructions
	Use foot protection
	Use hand protection
	Use eye protection
	Use head protection
	Use ear protection
	Earth prior to use

Term	Explanation
Plant	Part provided by the user in which the F-RRE/F-RLE is installed.
F-RRE/F-RLE = Radial blower	Ready to connect machine for vacuum and compression operations, for high volume flow rates with small pressure differentials.
Radial	Design / Operating principle of the F-RRE/F-RLE.
Volume flow	Volumes of air or gas that are moved by the F-RRE/F-RLE per unit of time or that flow through a pipe.
Substructure	Mounting plate, base frame or foundation on which the F-RRE/F-RLE is constructed.
Elastic / rigid	When the lowest normal frequency of the system, consisting of the F-RRE/F-RLE and substructure, lies at least 25% per measurement direction above the rotary frequency of the F-RRE/F-RLE, the substructure is considered to be rigid. All other substructures are considered to be elastic.
Assembly environment	Space in which the F-RRE/F-RLE is set up and operated (this may differ from the suction environment).
Suction/discharge environment	Chamber from which the media to be conveyed is suctioned or in which the media to be conveyed is expelled (this may differ from the assembly environment).
Vacuum operation	Operating mode whereby the - pressure at inlet $p_1 < p_{atm.}$ and - pressure at outlet $p_2 = p_{atm.}$
Compressor operation	Operating mode whereby the - pressure at inlet $p_1 = p_{atm.}$ and - pressure at outlet $p_2 > p_{atm.}$

## 1.4 Changes in comparison to the previous version

This document is the first edition.

The manufacturer is not liable for damage caused by the failure to observe these instructions and the related documents.

## 2.1 Explanation of warning signs

Warning sign	Explanation
⚠ <b>DANGER</b>	Danger that failure to observe the measures could lead to death or serious physical injuries.
⚠ <b>WARNING</b>	Danger that failure to observe the measures could lead to death or serious physical injuries.
⚠ <b>CAUTION</b>	Danger that failure to observe the measures could lead to minor physical injuries.
<b>NOTICE</b>	Danger that failure to observe the measures could lead to material damage.

## 2.2 Correct use of the equipment

The F-RRE/F-RLE is a continuous operation machine that is optimised for the generation of a vacuum and pressure. The protection class is stated on the Rating plate [→ 12].

The F-RRE/F-RLE:

- should only be used within the limits defined in this documentation. In particular, the limits in the following section must be observed:
  - Mounting conditions [→ 18]
  - Permitted conditions for use [→ 31]
  - Electrical data [→ 33]
- only operate when fully assembled and in a technically perfect condition.
- Can deliver the following conveyed media:
  - Air with a relative humidity of up to 90%
  - All non-explosive, non-combustible, non-abrasive and non-toxic gasses and gas/air mixtures, after consultation with the manufacturer
- May only be operated for short periods of time at full throttle or when not connected to a system.

Other operating conditions must be agreed with the manufacturer.

### 2.3 Improper operational modes

It is forbidden to:

- Operation in a potentially explosive area (ATEX).
- Connection in a potentially explosive area (ATEX).
- The conveyance of explosive, combustible, abrasive, unstable, oxidative or toxic media, e.g. dusts that do not accumulate in printing machines, solvents, as well as of fluids and solid matter of any type.
- Operation without a connected suction line.
- Use in non-industrial plants, unless essential precautions and protective measures have been taken.
- Mobile operation.
- Reverse operation.
- Use in areas with ionising or non-ionising radiation.
- Use in areas with ultrasound.
- Changes to the F-RRE/F-RLE and the accessories, that have not been agreed with the manufacturer.
- Operation outside of the limits defined in these instructions.
- Start-up and operation with an inadmissible overpressure or negative pressure from the plant, see Pressure differences [→ 32].
- Operation with closed pipes (closed slider).

### 2.4 Working in a safety-conscious manner

**Work at a standstill and Work on running or energised vacuum pumps/compressors can lead to serious injuries due to body parts being drawn in or crushed or death due to electric shock.**



Work on the F-RRE/F-RLE at a standstill only and in a de-energized condition.

1. Disconnect.
2. Secure to prevent it from being switched back on.
3. Make sure that it is de-energised.
4. Earth it and short-circuit it.
5. Cover or block off adjacent parts that are still supplied with voltage.

**Not fully assembled Operation with exposed parts can lead to serious injuries due to body parts being drawn in or crushed.**

1. Re-attach safety and protective devices and put them back into operation immediately after completion of work.
2. F-RRE/F-RLE should only be put into operation when fully assembled.

**Changes, additions and conversions Changes, additions and conversions may lead to unforeseeable risks and thus to serious injuries or death.**

Changes, additions and conversions to the F-RRE/F-RLE that are not described anywhere in the documentation must be authorised by the manufacturer.

Only use original parts or parts/auxiliary materials (grease, sealant) approved by the manufacturer. Using other parts and auxiliary materials can lead to unforeseeable hazards and may exempt the manufacturer from liability for the resulting consequences.

Keep all notices attached to the F-RRE/F-RLE in a clearly legible condition:

- Labelling of connections
- rotation arrows
- Rating plate
- Warning signs



## 2.5 Requirements for personnel

### 2.5.1 Staff qualifications and training



All those who will work on the F-RRE/F-RLE must have read and understood these instructions and the related documents.

Personnel in training may only work on the F-RRE/F-RLE under supervision of personnel who have the **required knowledge**.

Only personnel with the following knowledge may carry out the work described in these instructions:

Work task	Personnel	Required knowledge
Transportation, storage	Shipper, dealer, qualified personnel for transportation and storage	<ul style="list-style-type: none"> <li>Safe handling with lifting gear such as hoists and fork lift trucks</li> </ul>
Assembly, start-up, correcting faults, shut down, dismantling	Qualified personnel for radial blower	<ul style="list-style-type: none"> <li>Safe handling of tools</li> <li>Laying and connecting pipes and hoses</li> <li>Mounting mechanical components</li> <li>Knowledge of radial blower</li> </ul>
Working on the electrical system	Electrician	<ul style="list-style-type: none"> <li>Understanding and safe implementation of circuit diagrams</li> <li>Lay and connect electrical lines</li> <li>Connection of electrical machines, switches, sensors, circuit breakers</li> <li>Analysing and testing electrical systems</li> <li>Assessing the effectiveness of electrical protection measures</li> </ul>
Operation	Operating personnel, operators	<ul style="list-style-type: none"> <li>Instructions for occupational safety and for handling radial blowers</li> </ul>
Maintenance repair	Qualified personnel for maintenance and repair	<ul style="list-style-type: none"> <li>Safe handling of tools and materials</li> <li>Assembling and disassembling radial blowers</li> <li>Assessing damage to radial blowers</li> </ul>
Disposal	Qualified personnel for disposal	<ul style="list-style-type: none"> <li>Decontaminating polluted materials</li> <li>Re-use of materials and substances</li> <li>Correct and environmentally-friendly disposal of materials and substances</li> </ul>

### 2.5.2 Personal protective equipment



#### WARNING

**Danger of crushing and cutting!**



**Crushing and cutting of body parts due to sharp edges or falling parts on the open F-RRE/F-RLE.**



1. Wear protective gloves, safety footwear and safety goggles for all assembly and disassembly, troubleshooting and maintenance work.



2. In addition, wear head protection for transportation and overhead work.



#### WARNING

**Risk of injury!**

**Serious injuries due to body parts and hair being sucked or drawn in (vacuum) or due to projected particles (pressure).**

1. Wear eye protection and tight clothes for all work when in operation.

2. Wear a hair net for long hair.

3. Remove jewellery and rings.



#### WARNING

**Hearing damage!**

**Hearing damage due to time spent in the excessive noise area when there are adverse operating conditions or noise due to suddenly ejected conveyed media at the discharge nozzles or piping.**

① Wear ear protection when remaining in the excessive noise area.

## 2.6 Requirements of the operator



### WARNING

#### **Explosion and burst risk!**

**Any machine that is operated at a pressure or speed that is beyond that which is permitted, can explode or burst and cause serious injuries due to parts flying off and suddenly ejected conveyed media.**

1. The operator must ensure that the pressure differences [→ 32] that affect F-RRE/F-RLE are not exceeded.
2. The operator must ensure that the revolutions are not exceeded.

The operator ensures that:

- All work on the F-RRE/F-RLE is carried out by:
  - personnel that have the necessary Staff qualifications and training [→ 9]
  - personnel that have been sufficiently informed of these instructions and all related documents
- Assignment, responsibility and supervision of personnel is regulated.
- The content of these and locally applicable instructions are always available to personnel.
- Personnel are informed of the conveyed media and the emergency safety measures, so as to prevent injuries.
- All local and plant-specific safety measures are adhered to, such as:
  - Prevention of accidents
  - safety and operating regulations
  - Utility company regulations
  - Standards and laws
- Hot surfaces such as pipes and hoses are inaccessible during operation are provided with a suitable safeguard (e.g. perforated metal cover or wire covering) or are insulated.
- Hot surfaces, such as pipes and hoses, that do not have their own safeguard, are supplied with warning signs.
- The free drawing in or emission of the conveyed media does not place any personnel in danger.
- Dangers due to electrical energy are not possible.



## 3.1 Rating plate

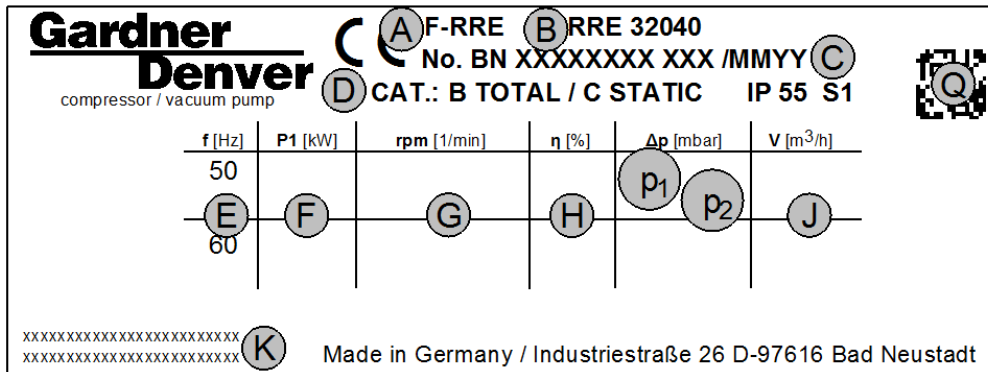

- |  |   |
|--|---|
| A Series   | H Efficiency  |
| B Type   | p Pressure differences  |
| C Serial number/year of manufacture                    | p <sub>1</sub> values with a negative sign apply to vacuuming and vacuum operations |
| D Efficiency category, protection class, thermal class | p <sub>2</sub> values with no sign apply to overpressure and compressor operation   |
| E Frequency  | J Volume flow   |
| F Motor output power                                   | K Manufacturer information, customer information (optional)                         |
| G Rated rpm  | Q Serial number/year of manufacture as QR code                                      |

### 3.2 Design of the machine

F-RRE

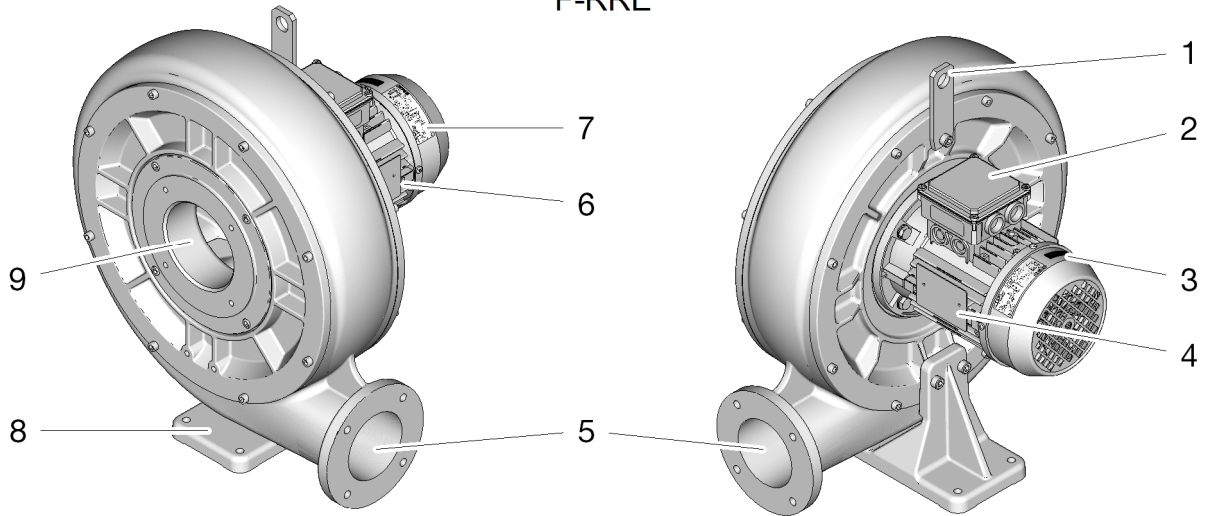

F-RLE

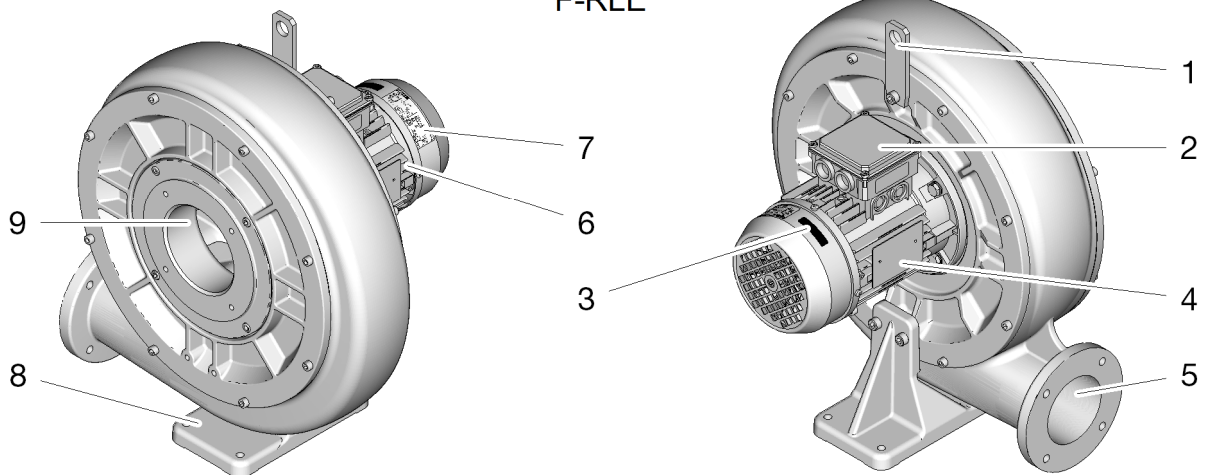

- 1 Lifting attachment
- 2 Terminal box
- 3 Direction of rotation arrow
- 4 Engine rating plate
- 5 Discharge-side connection

- 6 Motor
- 7 Rating plate
- 8 Foot
- 9 Suction side connection

### 3.3 Options

F-RRE

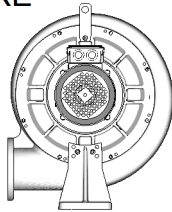

01

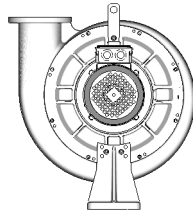

02

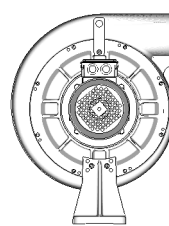

03

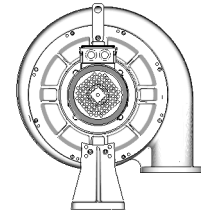

04

F-RLE

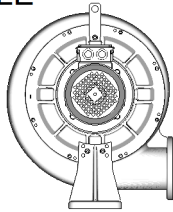

01

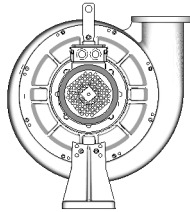

02

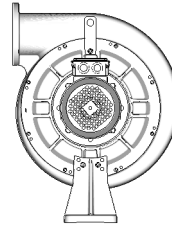

03

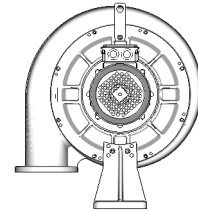

04

The F-RRE/F-RLE can be supplied with four different connection positions. Standard design is position 01.

### 3.4 Function principle

The F-RRE/F-RLE blower is a radial blower that works according to the dynamic compressing principle and operates with a non-contact rotating impeller. In principle, the blower can be used for suction or compression operations. The drive and the fan form a single unit. A shaft seal is arranged between the storage chamber and the compression chamber. The impellers are overhung and are located on the extended, vertical shaft of the motor. The motorised fan cools the housing of the engine and blower.

The types F-RRE rotate clockwise while the F-RLE rotate anti-clockwise.

### 3.5 EU declaration of conformity

#### EC declaration of conformity

**Gardner**  
**Denver**

**Manufacturer:** Gardner Denver Deutschland GmbH  
Industriestraße 26, 97616 Bad Neustadt, Germany

**Representative for the compilation of technical documents:** Holger Krause  
Industriestraße 26, 97616 Bad Neustadt, Germany

**Designation of the machine:** Compressor/Vacuum Pump

Series	F-RRE/F-RLE	
Types	F-RRE 26020	F-RLE 26020
	F-RRE 32010	F-RLE 32010
	F-RRE 32020	F-RLE 32020
	F-RRE 32040	F-RLE 32040
	F-RRE 53020	F-RLE 53020
	F-RRE 53050	F-RLE 53050
	F-RRE 62010	F-RLE 62010

**The manufacturer bears sole responsibility for issuing this declaration of compliance. The machine described above complies with all applicable harmonisation legislation of the Community:**

**2006/42/EC** European Parliament and Council Directive 2006/42/EC from 17th May 2006 on machinery and amending Directive 95/16/EC.

**2009/125/EC** Directive 2009/125/EC of the European Parliament and Council from 21 October 2009 establishing a framework for the setting of ecodesign requirements for energy-related products.

**harmonised standards and other technical specifications on which the declaration of compliance is based:**

**EN 1012-1:2010** Compressors and vacuum pumps - Safety requirements - Part 1: Compressors

**EN 1012-2:1996 +A1:2009** Compressors and vacuum pumps - Safety requirements - Part 2: Vacuum pumps

**EN ISO 12100:2010** Safety of machinery - General principles for design - Risk assessment and risk reduction (ISO 12100:2010)

Signed for and on behalf of: Gardner Denver Deutschland GmbH  
Bad Neustadt, 21.12.2015  
(Place and date of issue)



Andreas Bernklau, Product management/Authorised signatory  
(Name and function)

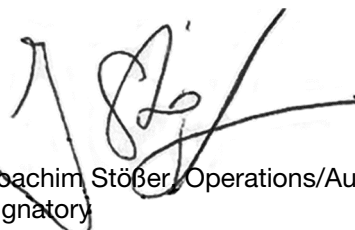

Joachim Stößer, Operations/Authorised signatory  
(Name and function)

664.00182.40.000

### 4.1 Unpacking and checking the condition of delivery

The F-RRE/F-RLE is secured onto a pallet and protected by a cardboard box for delivery.

1. Remove the packaging.  
**NOTICE! First remove the transport protection on the connection openings before connecting the pipes and hoses.**
2. Check F-RRE/F-RLE for transport damage.  
**NOTICE! Report any transport damage to the manufacturer immediately.**
3. Check whether the delivered F-RRE/F-RLE matches the order.
4. Check that accessories delivered with it are complete.
5. Remove the bands.
6. Dispose of packaging material in accordance with the valid local regulations.

### 4.2 Lifting and transporting

#### Transportation by crane

#### ⚠ WARNING

**Danger of crushing and cutting!**

**Danger of crushing and cutting of body parts due to tipping or falling loads during transportation.**

1. The load-bearing capacity of the lifting gear and load-handling devices must correspond to the Weight [→ 31] of the F-RRE/F-RLE.
2. Secure the F-RRE/F-RLE to prevent it from toppling or falling.
3. Do not remain under supported loads.
4. Set the F-RRE/F-RLE down on a horizontal surface.

#### *NOTICE*

**Mechanical damage!**

**F-RRE/F-RLE can be damaged during transportation due to impacts, tipping or falling over.**

1. The F-RRE/F-RLE should not be exposed to impacts and blows during transportation.
2. Secure the F-RRE/F-RLE from tipping or falling over.

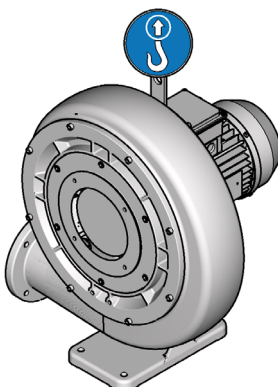

! All F-RRE/F-RLE are equipped with a lifting attachment (item 1, [→ 13]). This lifting attachment is exclusively designed for the mass of the F-RRE/F-RLE, including original accessories.

1. Check that the lifting attachment is firmly fastened and re-tighten as necessary.
2. Attach the crane hook to the lifting attachment.
3. Lifting and transporting the F-RRE/F-RLE.
4. Set the F-RRE/F-RLE down and, if necessary, secure from slipping and falling.
5. Remove the crane hook after transportation.



### 4.3 Storage

***NOTICE***

**Mechanical damage and corrosion!**

**Failure to adhere to the storage conditions can lead to mechanical damage and corrosion.**

1. Seal all openings so that no dirt or solid particles can enter.
2. Avoid storage for more than 6 months.
3. Adhere to storage and standstill conditions.

Storage and standstill conditions	Permitted values	
Ambient pressure	Atmospheric	
Composition of the environment	Dry, dust-free environment (relatively humid < 80%)	
Ambient temperature	<b>-10°C to +60°C</b>	14°F to +140°F
Static loads	None	
Abrupt impacts	None	
Speed of oscillation $V_{eff}$	<b>&lt;1.5 mm/s</b>	<0.059 in/s

## 5.1 Measures after long-term storage

### Measuring the motor insulation resistance

- ① Measuring the motor insulation resistance.
  - ✓ Value  $>1$  k $\Omega$  per volt of measured voltage: no measures necessary.
  - ✓ Value  $\leq 1$  k $\Omega$  per volt of measured voltage: Dry winding.

## 5.2 Reduction of oscillations and noises

Noise emissions and vibrations can be reduced by the following measures.

- Do not set up the F-RRE/F-RLE in set-up areas that conduct or radiate sound.
- Equip installation surfaces with intermediate layers of noise damping material.

## 5.3 Mounting conditions

For safe operation, comply with the following installation conditions

- No exhaust air from other machines in the suction area of the motor fan.
- Provide ventilation facilities, so that the permissible Temperatures [ $\rightarrow$  32] are not exceeded.
- Sufficient room is provided for installation and removal of pipelines and maintenance and repair work, particularly for removing and installing the F-RRE/F-RLE.
- Provide an even, stable installation surface or base frame whose dimensions and load-bearing capacity are designed for the F-RRE/F-RLE.
- External oscillations, abrupt loads and accelerations are not permitted.
- When installing outdoors, protective measures against the effects of weather such as rain, direct sunlight, lightening, snow or ice (e.g. a protective roof) must be provided.
- External mechanical loads are not permitted on the F-RRE/F-RLE and its attachments (e.g. piping without support, ascending the F-RRE/F-RLE and its attachments)
- For installation in enclosed spaces and for conveyed media other than air, leaks from the F-RRE/F-RLE must be considered (e.g. forced ventilation, gas monitoring).
- When loading the conveyed goods statically, ground the connection cables.
- When there is a risk of condensation formation in the internal space of the F-RRE/F-RLE, provide suitable protection measures (e.g. heating, upstream moisture separators, follow-up).

## 5.4 Set up

- The F-RRE/F-RLE must always be screwed to a fixed installation surface (e.g. floor, wall, ceiling) or to a base frame.

The F-RRE/F-RLE should only be set up on level units with the foot facing down on a fixed surface (e.g. floor) or a baseframe.

1. Mark the fixing points through the holes in the foot (item 8, [ $\rightarrow$  13]) or by referring to the dimensional drawing.
2. Lift the F-RRE/F-RLE away and drill the holes for the fixing points.
3. Place the F-RRE/F-RLE with the foot in assembly position.
4. Screw the foot to all anchorage holes with suitable fastening elements.

## 5.5 Connecting pipelines and hoses

 **WARNING**

**Risk of injury due to overpressure!**

**Suddenly ejected conveyed media such as impurities and solid particles or pressure surges can lead to serious injuries.**

1. Dimension pipes and hoses, securing elements, fittings and containers sufficiently and align them to the maximum pressures.
2. Connect the F-RRE/F-RLE and the system de-energised and flexibly (e.g. using hoses or compensators).
3. Do not fit pipes, hoses, securing elements, fittings and containers to the F-RRE/F-RLE and secure from damage.
4. Prevent the entry of solid particles and fluids in the F-RRE/F-RLE (clean pipes and hoses after assembly, use an extraction or in-line filter if necessary).
5. Protect the F-RRE/F-RLE from non-permitted pressure levels from the plant (e.g. pressure limiting valve, pressure switch).
6. For compressor operation, the pressure on the pressure connectors of the F-RRE/F-RLE must be monitored using a suitable pressure indicator. When the permissible discharge pressure is exceeded, switch the F-RRE/F-RLE off.
7. After switching off, ensure that no conveyed media can flow through the F-RRE/F-RLE (uncontrolled speed by conveyed media), install a check valve if necessary.
8. With a free-blowing pressure side, secure the danger area from hot conveyed media and projected particles with deflection plates or a collection basket.

 **WARNING**

**Serious injuries due to suction and drawing in of body parts and hair!**

- ① For free drawing in from the environment, provide safety measures that prevent the drawing in of body parts and hair.



 **WARNING**

**Risk of burns due to temperatures of up to approx. 160°C [320°F]!**

**Contact with hot surfaces, pipes and hoses, can lead to burns.**

1. Fit pipes and hoses with sufficient distance from highly inflammable materials (e.g. wood, plastic).
2. Provide hot surfaces, such as pipes and hoses with a suitable safeguard (e.g. perforated metal cover or wire covering) or isolate them.
3. Hot surfaces, such as pipes and hoses, that do not have their own safeguard, are supplied with warning signs.

**NOTICE**

**Pressure loss due to reduced cross section of the pipes and hoses!**

- ① As possible, make the cross section of the pipes and hoses the same length or longer than the connections of the F-RRE/F-RLE.

The conveyed media is suctioned via the suction side (item 9, [→ 13]) and discharged via the pressure side (item 5, [→ 13]).

The F-RRE/F-RLE can be fitted with pipes or hoses (internal threads).

! On delivery, all connection openings are closed with a transport protection. This prevents foreign objects from entering.

1. Remove the transport protection from the connection openings.
2. The suction side must always be connected with a pipe or a hose. Comply with minimum length according to **EN ISO 13857**.
3. If the pressure side is not connected with a pipe or a hose, the customer must provide sound protection measures or personal protective equipment.
4. For impurities in the conveyed media, fit a filter (accessories) in the suction line.
5. Connect the pipe or hose of the system pressure line to the pressure side connection (item 5, [→ 13]).
6. Connect the pipe or hose of the system suction line to the suction-side connection (item 9, [→ 13]).

## 6.1 General installation regulations

### NOTICE

#### **Destruction of the asynchronous motor due to incorrect electrical operation or incorrect control!**

! The F-RRE/F-RLE is equipped with an **asynchronous motor**.

① Adjust the electrical operation and control to the asynchronous motor.

The electrical installation must correctly fulfil the requirements of IEC 60204-1, IEC 60204-11 and IEC 61010-1 in accordance with the ambient and operating conditions.

The electrical installation must also be implemented according to the applicable national, local and plant-specific stipulations, as well as the requirements of the power supply company.

The conditions at the operating site must comply with the information on the Rating plate [→ 12]. The following deviations from EN 60034-1 (range A) are permitted for mains operation without loss of performance:

- $\pm 15\%$  variation in voltage
- $\pm 2\%$  deviation in frequency

The electrical installation must:

- Be correctly attached and protected.
- Be kept away from hot surfaces.
- Be electrically isolated to a sufficient degree.
- Be constructed and fitted in such a way that the following faults do not lead to damage:
  - short circuits
  - mechanical impacts
  - power supply failures or surges
  - electromagnetic fields
  - earth connections

The electrical equipment and control must not put the protective devices of the drive system and the motor protection (e.g. PTC resistor, bimetal switch, frequency inverter current limit) out of operation.

When the power supply fails or surges, the control must prevent the F-RRE/F-RLE from remaining in operation or starting up.

Protective devices and switches must fulfil the failure safety conditions.

#### **Overcurrent protection**

The power supply of the motor must be equipped with an overcurrent protection device (e.g. a motor protection circuit breaker) according to IEC 60204-1, 7.2. Electrical data, see Rating plate [→ 12].

#### **Separator for the electrical energy supply**

A separator for the electrical energy supply must be provided and:

- implemented according to IEC 60204-1, 5.3 and 5.5 (for electrical data, see Rating plate [→ 12]).
- The separator for the electrical energy supply must be clearly and visibly marked.

## 6.2 Controls

Controls and instruments must be constructed and arranged in such a way that:

- They are easily visible and accessible, and can also be operated without excessive effort.
- The operator understands the functions.
- Operating faults are prevented.

A control system must correspond to ISO 12100, 4.11; IEC 60204-1, 9.4 and ISO 13849-1.

When the power supply fails, a "system with oriented failure mode" according to ISO 12100, 6.2.12.3 must be used.

Start and stop devices must be clearly marked in accordance with ISO 13850 and IEC 60417.

### EMERGENCY OFF function

An EMERGENCY OFF function must be provided when a dangerous situation can occur that must be rectified manually (see ISO 12100, 6.3.5.2)

- Implement the EMERGENCY off function according to EN 418 and EN 50099.
- Implement a manual EMERGENCY OFF function according to ISO 13849-1, 5 (in particular 5.2.1).
- The stop category and colour of the EMERGENCY OFF function must correspond to ISO 13850.
- If a risk assessment determines that the normal switch can fulfil the EMERGENCY OFF function, this should be labelled accordingly.

After an EMERGENCY OFF, start-up is only possible via a deliberate, manually-triggered procedure.

### Manual reset

A manual reset after a stop command must correspond to ISO 13849-1, 5.5.2 and IEC 60204-1, 9.2.5.3 and 9.2.5.4.

### Start and new start

The requirements of a start and new start, must correspond to ISO 13849-1, 5.2.3.



If the F-RRE/F-RLE is equipped with an automatic or remote-controlled start control, it must be labelled with the sign to the left.

An automatic or remote-controlled start during maintenance or repair must be prevented by a latch, which is contained in the control system (e.g. key transfer system or protected password for software-controlled systems).

### 6.3 Prepare the motor terminal box

1. Open designated access points for cable gland.
2. Insert cable gland and secure with locknut.  
Fit reducer when using a positive temperature coefficient (PTC) resistor.

### 6.4 Connect the motor to the mains



1. Open the terminal box cover.
2. Connect the protective cable to the terminal with the symbol to the left.
3. Connect switch stirrup according to circuit diagram in (item 2, Design of the machine [→ 13]).

Note torque settings for terminal plate connections.

For connections with a terminal clip, route the conductor so that both pin ends are at approximately equal clip height.

Earth conductor and exterior earth conductor must be bent into a "U" shape. All other conductors must be bent into a "U" shape or connected using a suitable terminal end.

- ① Connect PTC resistor, bimetal switch and rest period according to the circuit diagram in the terminal box (item 2, Design of the machine [→ 13]). Use a suitable PTC resistor evaluation unit for the evaluation of the PTC resistor.
- ① Close the terminal box cover.

## 7.1 Measures after a long shut-down period

### Measuring the motor insulation resistance

- ① Measuring the motor insulation resistance.
  - ✓ Value  $>1 \text{ k}\Omega$  per volt of measured voltage: no measures necessary.
  - ✓ Value  $\leq 1 \text{ k}\Omega$  per volt of measured voltage: Dry winding.

## 7.2 Tests during commissioning or re-commissioning

Prior to commissioning or re-commissioning of the F-RRE/F-RLE, test that

- Is the F-RRE/F-RLE properly fitted and aligned?
- all pipes and hoses are correctly connected and sealed
- all fixing screws, connecting elements and electrical connections are fixed at the given tightening torques
- Do the operating conditions match the data plate details given above?
- Have all protection measures been completed?
- Cooling air supply not affected?
- Is the auxiliary ventilator ready for operation?

## 7.3 Check the direction of rotation

1. Switch on the F-RRE/F-RLE briefly and then switch it off again.
2. Match the direction of rotation of the fan impeller on the motor ventilator to the direction of rotation arrow (item 3, [→ 13]).
  - ✓ Direction of rotation matches the direction of rotation arrow: no measures
  - ✓ Direction of rotation does not conform with direction of rotation arrow: Change direction of rotation by interchanging two phases of electrical supply line



## 7.4 Power adjustment

### NOTICE

**The motor has been overloaded!**

**Destruction to the motor due to overload during operation.**

! Keep in mind the following when putting the F-RRE/F-RLE into operation:

1. Operating the F-RRE/F-RLE without a connection on the suction or pressure side is not permitted.
2. When the volume flow can be adjusted in the system (e.g. taps or dampers), set the highest possible volume flow during operation. The highest load is placed on the motor in this state.
3. Check mains voltage and mains frequency.
  - ✓ If the mains voltage and mains frequency vary from the entries on the motor's rating plate (item 4, [→ 13]), check the mains connection.
  - ✓ If the mains voltage and mains frequency match the entries on the motor's rating plate, move on to the next step.
4. Check rated current. The rated current is crucial for the capacity of the motor.
  - ✓ If the rated current is complied with, then no further measures are necessary.
  - ✓ If the rated current is exceeded, then the volume flow is higher than permitted. The power must be adjusted using the throttle. Move on to the next step.
5. If the system does not have its own throttle function (e.g. reducing the intake and discharge openings, increasing the flow resistance), then one of the following throttle measures is required:
  - ✓ Use of a throttle plate in the piping. This throttle plate must reduce the interior diameter of the piping far enough that the rated current can no longer be exceeded.
  - ✓ Use of a throttle valve. Close the throttle valve to the point where the rated current is no longer exceeded. Lock the position of the valve permanently.

When operating the F-RRE/F-RLE comply with the Permitted conditions for use [→ 31].

## 8.1 Switch on

1. If fitted, open the shut-off devices in the suction line.
2. Switch on current supply.
  - ✓ The F-RRE/F-RLE begins to suction conveyed media.

## 8.2 Switch off

1. Switch off current supply.
  - ✓ The F-RRE/F-RLE interrupts the suction of the conveyed media. The pressure will be slowly reduced.
  - ✓ The F-RRE/F-RLE slowly shuts down.
2. If fitted, close the shut-off devices in the suction line.

## 8.3 Switch off in emergency

1. The F-RRE/F-RLE can be switched off in emergency without any particular precautions.
  - ✓ The F-RRE/F-RLE slowly shuts down.
2. Determine the cause.
3. Rectify the risk.
4. Put the F-RRE/F-RLE back into operation [→ 24].

**⚠ WARNING**

**Danger of crushing and cutting as well as burns!**

**Work on the F-RRE/F-RLE when it is running can lead to serious injuries.**

**Contact with hot surfaces, pipes and hoses, can lead to burns.**

1. Switch the F-RRE/F-RLE off and disconnect it from the power supply.
2. Wait until the impeller stops.
3. Allow F-RRE/F-RLE to cool down.
4. Use personal protective equipment.

**Voiding of the warranty!**

**The opening of the F-RRE/F-RLE by the operator within the warranty period can lead to voiding of the warranty.**

<b>Fault</b>	<b>Cause</b>	<b>Corrective measure</b>	<b>To be carried out by</b>
F-RRE/F-RLE does not run and does not make any noise.	Power supply failure of the F-RRE/F-RLE.	① Correct the break in fuses, terminals or power supply lines.	Electrician
F-RRE/F-RLE does not start up and makes noises.	Failure in one of the power supply lines.	① Correct the break in fuses, terminals or power supply lines.	Electrician
	Impeller rubs or rotor is jammed.	① Open F-RRE/F-RLE, remove foreign objects, clean or replace parts.	Service*
	Impeller faulty.	① Replace impeller.	Service*
	Rolling bearing is faulty.	① Replace the rolling bearing.	Service*
Overcurrent protection triggered again after switching motor on; power consumption too high	Motor overloaded. Settings deviate from details on rating plate.	① Reduce settings.	Qualified personnel
	Short-circuit in winding.	① Check windings.	Electrician
	F-RRE/F-RLE aspirates freely.	① Connect system.	Qualified personnel
	Impeller rubs or rotor is jammed.	① Open F-RRE/F-RLE, remove foreign objects, clean or replace parts.	Service*
Suction power too low	Incorrect direction of rotation.	① Check the direction of rotation.	Electrician
	Suction line too long or cross-section too small.	① Check suction line.	Qualified personnel
	Fluctuating density of conveyed media.	① Take into account recalculation of pressure values. Consult the manufacturer.	Manufacturer
	Leaks in the F-RRE/F-RLE or system.	① Seal F-RRE/F-RLE or system.	Qualified personnel
F-RRE/F-RLE becomes too hot	Ambient temperature or suction temperature is too high	① Adhere to the Permitted conditions for use [→ 31].	Qualified personnel
	F-RRE/F-RLE aspirates too little air.	① Check the direction of rotation and the cross-sections of the lines.	Qualified personnel

## 9 Troubleshooting

Fault	Cause	Corrective measure	To be carried out by
Abnormal running noises or oscillations	Feet (item 8, [→ 13]) are defective	① Replace feet.	Qualified personnel
	Rolling bearing in the motor or in the blower component is defective.	① Replace the rolling bearing.	Service*

\* Correction by qualified personnel for repair is possible when the repair manual is available.

## 10.1 Maintenance

**⚠ WARNING**

**Danger of crushing and cutting as well as burns!**

**Work on the F-RRE/F-RLE when it is running can lead to serious injuries.**

**Contact with hot surfaces, pipes and hoses, can lead to burns.**

1. Switch the F-RRE/F-RLE off and disconnect it from the power supply.
2. Wait until the impeller stops.
3. Allow F-RRE/F-RLE to cool down.
4. Use personal protective equipment.

For the safe operation of the F-RRE/F-RLE, the following maintenance intervals are recommended. They are dependent on the operating conditions and must be adjusted by the user as necessary.

Maintenance interval	Maintenance measure	To be carried out by
Depending on the concentration of contaminant particles (at least monthly)	① Check the fan guard and cooling ribs of the motor for dirt and if necessary clean with pressurised air.	Operating personnel

## 10.2 Repairs and complaints

Please consult the service department regarding repairs and complaints before sending them to the manufacturer.

- Gardner Denver Deutschland GmbH  
Industriestraße 26  
97616 Bad Neustadt  
Tel.: +49 9771 6888 2000  
Fax: +49 9771 6888 11 2000  
E-mail: er.service-nes@gardnerdenver.com  
Internet: www.gd-elmorietschle.com

## 11.1 Decommissioning

### WARNING

**Danger of crushing and cutting as well as burns!**

**Work on the F-RRE/F-RLE when it is running can lead to serious injuries.**

**Contact with hot surfaces, pipes and hoses, can lead to burns.**

1. Switch the F-RRE/F-RLE off and disconnect it from the power supply.
2. Wait until the impeller stops.
3. Allow F-RRE/F-RLE to cool down.
4. Use personal protective equipment.

! The F-RRE/F-RLE can remain in the unit or be dismantled for storage.

1. Disconnect the F-RRE/F-RLE from the power supply.
2. Depressurise the pipes.
3. Store [→ 17] or disassemble F-RRE/F-RLE (Disposal [→ 30]).

## 11.2 Disassembly

1. Disconnect the F-RRE/F-RLE from all electrical connections.
2. Dismantle the piping and hoses.
3. Close connections that are open.
4. Loosen the F-RRE/F-RLE from the installation surface.
5. store [→ 17] or dispose [→ 30] of F-RRE/F-RLE.

## 11.3 Disposal

### WARNING

**Burns, chemical burns or poisoning!**

**Burns, chemical burns or poisoning due to contact with harmful substances remaining in the F-RRE/F-RLE.**

- ① Decontaminate the F-RRE/F-RLE as instructed by the manufacturer of the hazardous substances.

! When performing disposal, adhere to the following:

1. Dismantle the F-RRE/F-RLE.
2. Collect liquids and grease and dispose of them separately in accordance with the valid local regulations.
3. Dispose of components according to the valid local regulations or recycle them.

## 12.1 Mechanical data

### 12.1.1 Weight

Type	[kg]	[lbs]
F-RRE/F-RLE 26020	<b>16</b>	36
F-RRE/F-RLE 32010	<b>21</b>	47
F-RRE/F-RLE 32020	<b>22</b>	48.5
F-RRE/F-RLE 32040	<b>28</b>	62
F-RRE/F-RLE 53020	<b>67</b>	148
F-RRE/F-RLE 53050	<b>102</b>	225
F-RRE/F-RLE 62010	<b>82</b>	181

### 12.1.2 Tightening torque values

The values apply if no other specifications are available.

#### Stainless steel screws

Mechanical properties A4-70 according to ISO 3506-1.



Thread	[Nm]	[ft lbs]
M4	<b>1.0 – 1.2</b>	0.80 – 1.20
M5	<b>2.3 – 2.7</b>	1.70 – 2.70
M8	<b>7.5 – 9.0</b>	5.55 – 6.65
M10	<b>18 – 22</b>	13.3 – 16.2

#### Cable and wiring screw connections



Thread	Metal		Plastic	
	[Nm]	[ft lbs]	[Nm]	[ft lbs]
M12x1.5	<b>4.0 – 6.0</b>	2.95 – 4.42	<b>2.0 – 3.0</b>	1.48 – 2.21
M16x1.5	<b>5.0 – 7.5</b>	3.69 – 5.53	<b>2.0 – 3.0</b>	1.48 – 2.21
M25x1.5	<b>6.0 – 9.0</b>	4.42 – 6.64	<b>2.0 – 3.0</b>	1.48 – 2.21
M32x1.5	<b>8.0 – 12</b>	5.90 – 8.85	<b>4.0 – 6.0</b>	2.95 – 4.42
M40x1.5	<b>8.0 – 12</b>	5.90 – 8.85	<b>4.0 – 6.0</b>	2.95 – 4.42

## 12.2 Permitted conditions for use

Any deviations from the following **permissible operating conditions** must be agreed with the manufacturer.

### 12.2.1 Installation height

The maximum installation height is **1000 m above sea level. NHN** (3280 ft above sea level) provided that no other installation altitude is specified on the Rating plate [→ 12] under item K.

### 12.2.2 Rotational speeds

For maximum revolutions, see item K, Rating plate [→ 12]

### 12.2.3 Temperatures

Different temperatures are indicated on the rating plate [→ 12] under item K.

#### Temperature of the conveyed media

Minimum		Maximum	
[°C]	[°F]	[°C]	[°F]
-10	14	+40	+104

#### Ambient temperature

Minimum		Maximum	
[°C]	[°F]	[°C]	[°F]
-10	14	+40	+104

### 12.2.4 Pressure differences

#### Pressure differences generated in operation by F-RRE/F-RLE

Vacuum mode, maximum [mbar]
Item p <sub>1</sub> , Rating plate [→ 12]

The pressure differences given on the rating plate have a tolerance of ±10% and apply to the permissible operating conditions [→ 31] and to the conveyed media of air.

Loss of piping must be considered.

### 12.2.5 Relative humidity

#### Ambient relative humidity

Maximum **60%** at **+40°C** (+104°F)

#### Relative humidity of conveyed media

Condensate formation is not permitted in the internal space of the F-RRE/F-RLE.

### 12.2.6 Minimum distances

Adhere to the following minimum distances for heat dissipation:

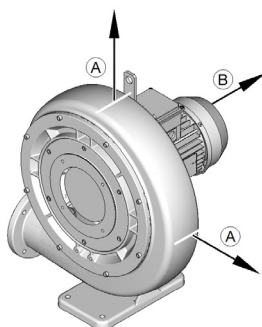

Type	A		B	
	[mm]	[in]	[mm]	[in]
F-RRE/F-RLE	<b>200</b>	8.0	<b>200</b>	8.0



### 12.3 Electrical data

Any deviations from the following **electrical data** must be agreed with the manufacturer.

The electrical data are provided on the Rating plate [→ 12].

#### 12.3.1 Increased operating cycle frequency

The F-RRE/F-RLE is designed for heavy-duty operation. Consultation with the manufacturer is necessary for increased operating cycle frequency.

### 12.4 Acoustic emissions

**Emission sound pressure level  $L_{pA}$**  according to noise test code ISO 2151 with reference to the basic standard ISO 3744. Measured at a distance of 1 m for 70%  $\Delta p_{max}$  and connected supply lines, tolerance  $\pm 3$  dB(A).

Type	50 Hz	60 Hz
	[dB(A)]	[dB(A)]
F-RLRE/F-RLE 26020	72	73
F-RLRE/F-RLE 32010	74	75
F-RLRE/F-RLE 32020	76	77
F-RLRE/F-RLE 32040	78	79
F-RLRE/F-RLE 53020	84	86
F-RLRE/F-RLE 53050	88	90
F-RLRE/F-RLE 62010	89	90

**Sound power level  $L_w$**  according to noise test code ISO 2151 with reference to the basic standard ISO 3744. Measured at a distance of 1 m for 70%  $\Delta p_{max}$  with the suction side connected and a free-blowing discharge side, tolerance  $\pm 3$  dB(A).

Type	50 Hz	60 Hz
	[dB(A)]	[dB(A)]
F-RLRE/F-RLE 53020	95	97
F-RLRE/F-RLE 53050	99	101
F-RLRE/F-RLE 62010	98	99



[www.gd-elmorietschle.de](http://www.gd-elmorietschle.de)  
[er.de@gardnerdenver.com](mailto:er.de@gardnerdenver.com)

---

**Gardner Denver  
Deutschland GmbH**  
Industriestraße 26  
97616 Bad Neustadt · Deutschland  
Tel. +49 9771 6888-0  
Fax +49 9771 6888-4000

Elmo Rietschle is a brand of Gardner Denver

**Gardner  
Denver**

Your Ultimate Source for Vacuum and Pressure